

CHEMICAL PLANT & ENGINEERING

A division of CEM International Pty Ltd
A.C.N. 004 933 135 A.B.N. 24 004 933 135

Head office 63-65 Maffra Street, Coolaroo, Victoria 3048 Australia
Postal P.O. Box 160, Dallas, Victoria 3047 Australia
Telephone +61 3 9309 4822 | **Fax** +61 3 9309 0069
Email cem@cem-int.com.au | **Web** www.cem-int.com.au



CHEMICAL PLANT & ENGINEERING

CLAMP – MOUNTED AGITATOR SELECTION CHART

Tank Volume (Litres)	Viscosity (cP)	<100	100 - 250	250 - 500	500 – 1000
100 – 200		PB-5/1 PG-5/1/220 PG-2/1/255	PB-5/1 PG-5/1/255 PG-2/1/305	PA-7/1 PG-5/1/255 PG-2/1/355	PA-7/2 PG-5/1/280 PG-2/1/370
200 – 500		PB-5/1 PG-5/1/255 PG-2/1/280	PA-7/1 PG-5/1/280 PG-2/1/330	PB-5/2 PG-5/1/305 PG-5/2/255 PG-2/1/370 PG-2/2/305	PG-5/1/330 PG-2/2/330
500 – 1000		PA-7/1 PB-5/2 PG-5/1/280 PG-5/2/220 PG-2/1/330 PG-2/2/255	PB-5/2 PG-5/1/305 PG-5/2/255 PG-2/1/370 PG-2/2/305	PA-7/2 PG-5/1/330 PG-5/2/280 PG-2/2/355	PG-5/2/305 PG-2/2/370
1000 – 1500		PB-5/2 PG-5/1/305 PG-5/2/220 PG-2/1/330 PG-2/2/280	PA-7/2 PG-5/1/355 PG-5/2/280 PG-2/2/330	PG-5/1/370 PG-5/2/330 PG-2/2/370	PG-5/2/330
1500 – 2000		PB-5/2 PA-7/2 PG-5/1/330 PG-5/2/255 PG-2/1/370 PG-2/2/305	PG-5/1/370 PG-5/2/305 PG-2/2/370	PG-5/2/330	PG-5/2/355
2000 - 3000		PB-7/2 PG-5/1/370 PG-5/2/305 PG-2/2/355	PG-5/2/330	PG-5/2/355	PG-5/2/370
3000 – 4000		PG-5/1/370 PG-5/2/330 PG-2/2/370	PG-5/2/355	PG-5/2/370	
4000 – 6000		PG-5/2/330 PG-5/2/355 PG-2/2/370	PG-5/2/370		
6000 – 8000		PG-5/2/355 PG-5/2/370			
8000 - 10000		PG-5/2/370			



AGITATOR DETAILS

Model	Installed Power (kW)	Shaft Speed (rpm)	Impeller Diameter (mm)	Number of Impellers	Pumping Rate (litres/min)	Absorbed Power (kW)	Max. Shaft Length (mm)
PA-7/1	0.55	1380	25.4	1	2,333	0.23	1500
PA-7/2	0.55	1380	25.4	2	4,666	0.45	1500
PB-5/1	0.37	918	25.4	1	1,550	0.09	1500
PB-5/2	0.37	918	25.4	2	3,100	0.18	1500
PG-5/1/220	0.37	247	25.4	1	1,316	0.008	1500
PG-5/2/220	0.37	247	25.4	2	2,631	0.015	1400
PG-5/1/255	0.37	247	25.4	1	2,051	0.018	1500
PG-5/2/255	0.37	247	25.4	2	4,102	0.035	1300
PG-5/1/280	0.37	247	25.4	1	2,716	0.028	1400
PG-5/2/280	0.37	247	25.4	2	5,431	0.055	1300
PG-5/1/305	0.37	247	25.4	1	3,510	0.041	1400
PG-5/2/305	0.37	247	25.4	2	7,021	0.082	1300
PG-5/1/330	0.37	247	25.4	1	4,447	0.061	1400
PG-5/2/330	0.37	247	25.4	2	8,893	0.12	1300
PG-5/1/355	0.37	247	25.4	1	5,536	0.09	1400
PG-5/2/355	0.37	247	25.4	2	11,072	0.18	1200
PG-5/1/370	0.37	247	25.4	1	6,265	0.11	1300
PG-5/2/370	0.37	247	25.4	2	12,530	0.22	1200
PG-2/1/255	0.18	148	25.4	1	1,229	0.004	1900
PG-2/2/255	0.18	148	25.4	2	2,458	0.008	1800
PG-2/1/280	0.18	148	25.4	1	1,627	0.006	1900
PG-2/2/280	0.18	148	25.4	2	3,254	0.013	1800
PG-2/1/305	0.18	148	25.4	1	2,103	0.009	1900
PG-2/2/305	0.18	148	25.4	2	4,207	0.018	1800
PG-2/1/330	0.18	148	25.4	1	2,664	0.014	1900
PG-2/2/330	0.18	148	25.4	2	5,329	0.028	1700
PG-2/1/355	0.18	148	25.4	1	3,317	0.019	1800
PG-2/2/355	0.18	148	25.4	2	6,635	0.038	1700
PG-2/1/370	0.18	148	25.4	1	3,754	0.024	1800
PG-2/2/370	0.18	148	25.4	2	7,508	0.048	1600

SIZING BASIS

Tank volume based on liquid level (actual liquid volume)

Specific gravity of liquid = 1.5

Viscosity of liquid = maximum in range

Agitation scale = 2 for maximum in volume range



PORTABLE AGITATOR SELECTION CHART

Use this chart for a quick method of selecting portable agitators.

Viscosity / Volume

Volume (litres) →

Viscosity Centipoise ↓	200 litres	400 litres	800 litres	2000 litres	4000 litres	8000 litres	12000 litres	20000 litres
1	PB-5/1	PB-5/1	PA-7/1	PB-5/2	PA-7/2	PA-7/2		
100	PB-5/1	PA-7/1	PA-7/1	PB-5/2	PA-7/2			
300	PB-5/1	PA-7/1	PB-5/2	PA-7/2				
500	PA-7/1	PA-7/2						
1000	PA-7/2							
2000								
3000								
5000								

Chart is based on following conditions:

- Medium agitation
- Specific gravity max = 1.5
- If the tank height exceeds 1.4 times the diameter use dual impellers.

PA-7/1	Portable Agitator	4 pole motor	1380 rpm	1 impeller
PA-7/2	Portable Agitator	4 pole motor	1380 rpm	2 impellers
PB-5/1	Portable Agitator	6 pole motor	918 rpm	1 impeller
PB-5/2	Portable Agitator	6 pole motor	918 rpm	2 impellers

Note:

If you have any special requirements or are not sure of your selection, please consult with our Sale Department for the selection of the most effective and economical agitator.



MOUNTING

Improper mounting of your portable agitator will significantly decrease mixing efficiency.

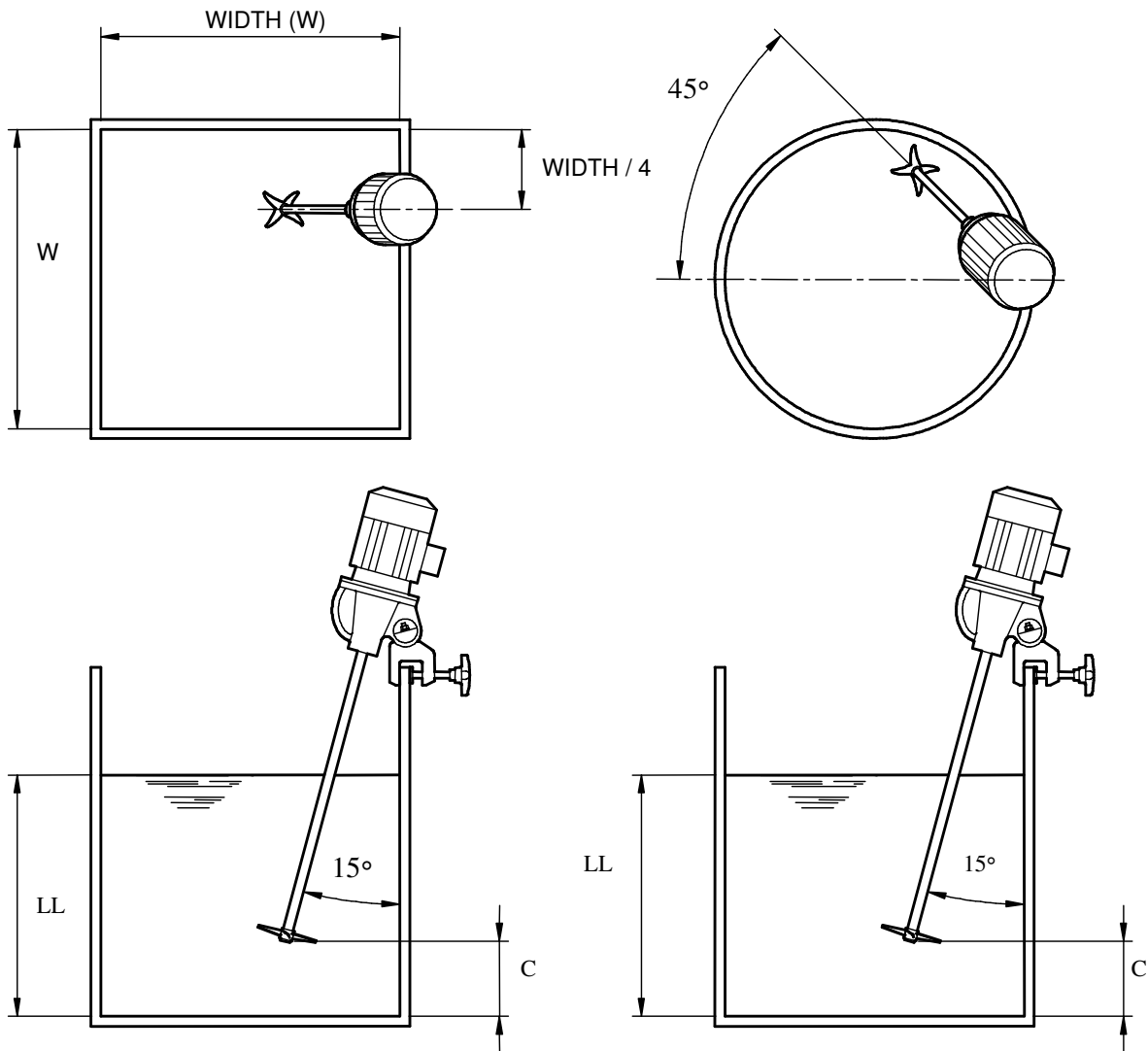

Note:

- C = clearance
- Standard clearance: $LL / 3$
- Low level clearance: $LL / 6$